

Micrometer Stands SERIES 156

Typical application



156-101-10

- Dedicated stand for micrometers.



156-101-10

- Designed to allow benchtop use of hand-held micrometers or other gages which have frames suitable for gripping by the clamp. Reduces the influence of temperature changes due to body heat, enabling higher-accuracy measurement.

SPECIFICATIONS

| Code No. | Measuring range of standard outside micrometer | Remarks |
|------------|--|-----------------------|
| 156-101-10 | 15 - 100 mm (0.6 - 4 in)* | Adjustable angle type |

* Items that cannot be mounted on these stands (Code No. 406-253-30, 323-253-30, 331-254-30, 342-254-30, 342-264-30, 369-253-30, 422-232-30, 422-233-30, etc.)

DIMENSIONS

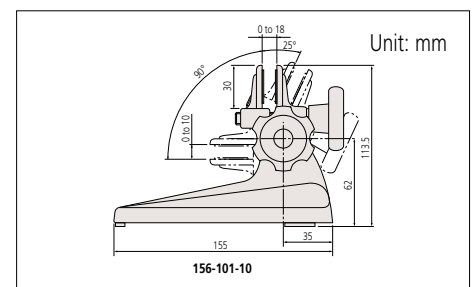

Typical application



156-105-10

SPECIFICATIONS

| Code No. | Measuring range of standard outside micrometer | Remarks |
|------------|--|------------------|
| 156-105-10 | 25, 50 mm (1, 2 in) | Fixed angle type |



156-105-10

DIMENSIONS

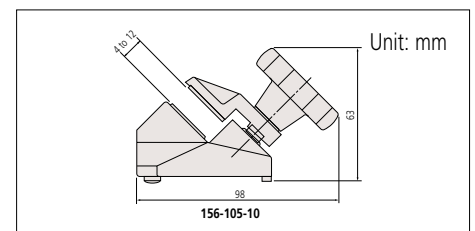

Typical application



156-102

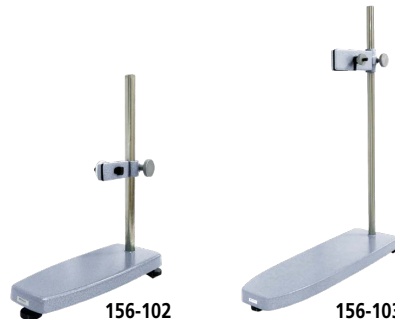

156-102

156-103

SPECIFICATIONS

| Code No. | Measuring range of standard outside micrometer | Remarks |
|----------|--|---------------|
| 156-102 | 100 - 300 mm (4 - 12 in) | Vertical type |
| 156-103 | 325 - 1000 mm (13 - 40 in) | Vertical type |

DIMENSIONS

